

WEICHAI



Weichai Official Website

Add:197A Fushou East Street,Weifang high-new technology
industrial development zone,Weifang,Shandong,China.

Tel:+86-536-8269988

Fax:+86-536-8232079

P.C:261000 China

E-mail:swiec@weichai.com

Website: www.weichai.com

WEICHAI
Bus Engine

CONTENTS

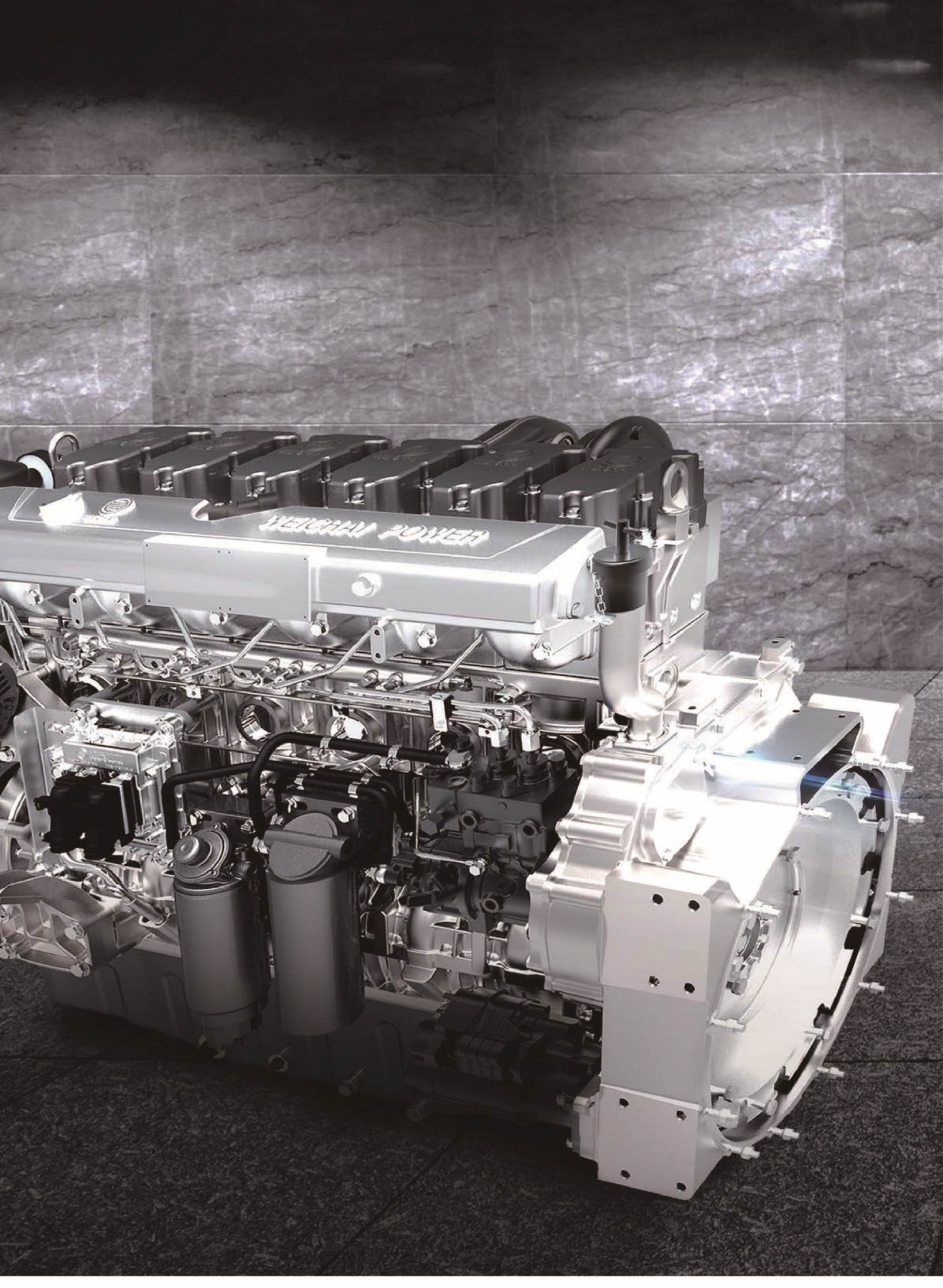

About us	01
R&D capacity	02
Bus engine portfolios	03
Engine model list	05
Major product introduction	09
Weichai Service	19

ABOUT US

Introduction

Weichai has four business platforms covering vehicle, power train, luxury yacht and auto parts. Its subsidiaries are spread across Europe, North America, Southeast Asia and other regions. Global R&D and Operation Centers are established in Chicago, Marseilles, Forli, Frankfurt and Singapore. At present, Weichai has offices in more than 30 countries and over 400 authorized service stations. Weichai products has been sold to 100 countries and regions around the world. Weichai is committed to extending its industry supply chain and improving its competitiveness through strategic investments. Weichai



acquired French Baudouin in 2009, further expanding engine business. In 2012, Weichai Group acquired 75 percent of Italy's Ferretti, the world's largest luxury yacht manufacturing enterprise. Later in 2012, Weichai Group's subsidiary, Weichai Power, signed a strategic cooperation agreement with KION Group, one of the world's top industrial forklift truck manufacturers and global leader of the hydraulic technology. Weichai aims to provide maximum satisfaction through its full range of engine and power offerings.

The most advanced manufacturing base of engines in the world

Weichai has an Industrial Park covering 220 hectares. Phase I invested 150 Million USD and 200,000 engines are produced per year. Phase II invested 140 Million USD and 150,000-ton castings are produced per year. All facilities are imported from world famous companies such as Heller of Germany, ATLAS and ABB of Switzerland and TOYOTA of Japan. ALL facilities on the product line are connected by LAN, which manages production in realtime. The lines include 50 machining centers, 8 robots, 5 fine finishing centers and CMM. All equipment is imported from Heller of Germany and TOYOTA of Japan.



R&D Capacity

Global Layout

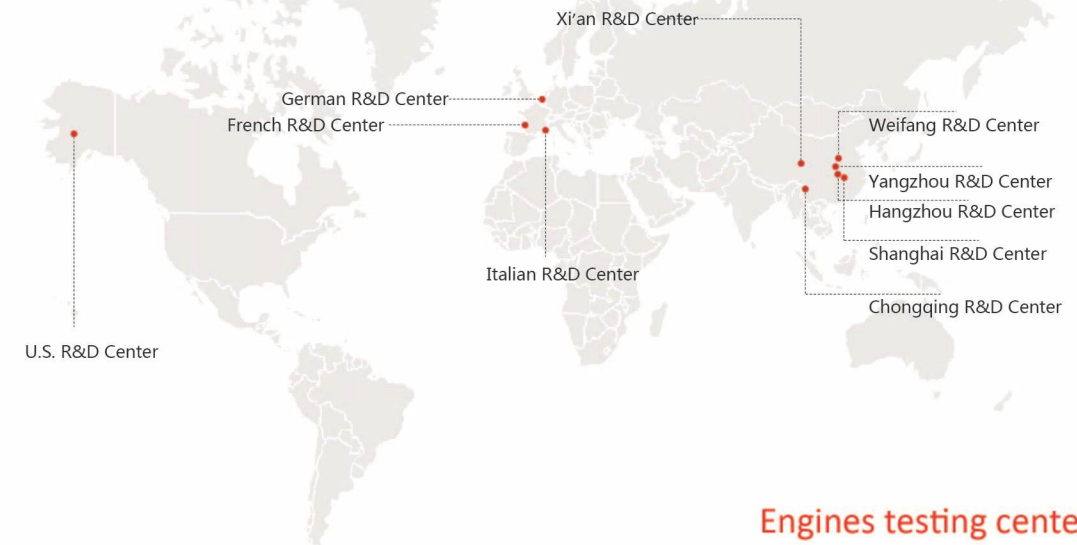

Engines testing center development

- Engines testing center at a cost of \$ 300 million to build, covers an area of 5,000 square meters, construction area of 10,000 square meters, is currently the largest, most versatile and the strongest engine test center.

- Germany TUV authorized laboratory
China National Accreditation Service for Conformity Assessment (CNAS) authorized laboratory
National key laboratory of internal combustion engine reliability



R&D Guarantee

Simulating Calculation	Five-axis test-bed	Vehicle hub rotation	Performance optimization
Provide theoretical support	Convenient and efficient matching test	Provide accurate test data	Promote power train performance
			

Three-height test team



Qinghai-Tibet Plateau of 4000 meters altitude

82°C Dunhuang desert

-40°C Heihe snowfield

Team
30 people

Mission
To provide customers with a broad geographical adaptability, high-performance and high-quality products.

Overview - Engines for Bus Equipment

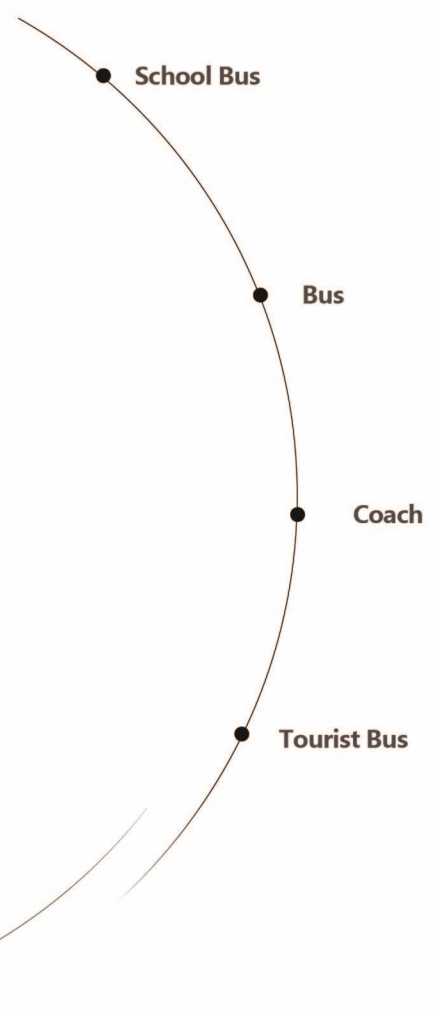

Euro V diesel engine for bus

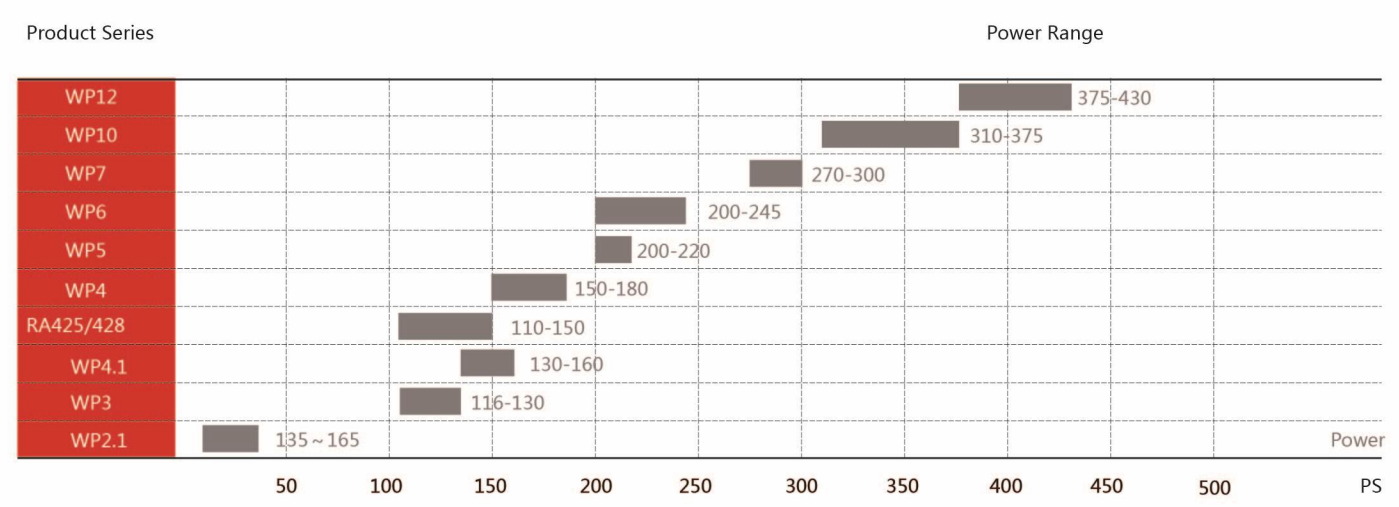

Technical route : Common rail +SCR

Euro V gas engine for bus

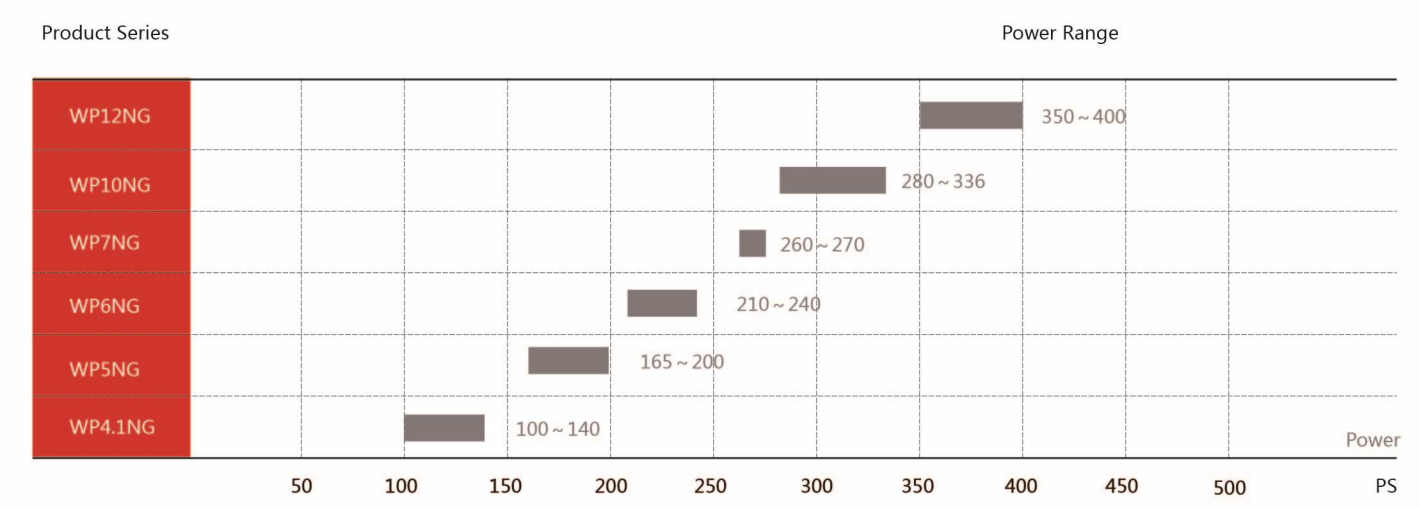

Technical route : Single point injection +Oxidation catalysis

MODEL LIST

WP2.1/WP3/WP3.7/WP4.1/WP4/6/WP5/7/WP9H/10H/WP10/WP12 Model List for Bus Engine
Gas Engine Model List for Bus Engine



WP2.1 Model List

Series	Model	Emission	Displacement (L)	Per cylinder valve	Rated power/speed (kW/rpm)	Max.torque/speed (N.m/rpm)	Technical route
WP2.1	WP2.1Q61	Euro V	2.1	2	45/3200	165/1700 ~ 2300	Common rail+SCR
	WP2.1Q71				52/3200	185/1700 ~ 2300	
	WP2.1Q82				60/3200	215/1700 ~ 2300	
	WP2.1Q95				70/3200	245/1700 ~ 2300	

WP3 Model List for

Series	Model	Emission	Displacement (L)	Per cylinder valve	Rated power/speed (kW/rpm)	Max.torque/speed (N.m/rpm)	Technical route
WP3	WP3Q95	Euro IV	2.1	2	70/3000	270/1400-1800	Common rail +EGR+DOC+POC
	WP3Q110				81/3000	310/1400-1800	
	WP3Q116				85/3000	340/1400-1800	
	WP3Q124				91/3000	350/1400-1800	
	WP3Q130				96/3000	350/1400-1800	
	WP3Q110	Euro V			81/3000	310/1400 ~ 1800	Common rail+SCR
	WP3Q116				85/3000	340/1400 ~ 1800	
	WP3Q124				91/3000	350/1400 ~ 1800	
	WP3Q130				96/3000	350/1400 ~ 1800	

WP3.7 Model List

Series	Model	Emission	Displacement (L)	Per cylinder valve	Rated power/speed (kW/rpm)	Max.torque/speed (N.m/rpm)	Technical route
WP3.7	YZ4DA3-40	Euro IV	3.7	2	75/2900	285/1400-1800	Common rail +EGR+DOC+POC
	YZ4DA2-40				83/2900	320/1400-1800	
	YZ4DA1-40				95/2900	350/1400-1800	
	WP3.7Q102	Euro V			75/2900	285/1400 ~ 1800	Common rail+SCR
	WP3.7Q113				83/2900	320/1400 ~ 1800	
	WP3.7Q130				96/2900	380/1400 ~ 1800	

WP4.1 Model List

Series	Model	Emission	Displacement (L)	Per cylinder valve	Rated power/speed (kW/rpm)	Max.torque/speed (N.m/rpm)	Technical route
WP4.1	YZ4DB3-40	Euro IV	4.1	2	85/2600	320/1400-1800	Common rail +EGR+DOC+POC
	YZ4DB2-40				90/2600	350/1400-1800	
	YZ4DB1-40				97/2600	400/1400-1800	
	WP4.1Q130	Euro V			97/2600	420/1200 ~ 1800	Common rail+SCR
	WP4.1Q140				103/2600	450/1200 ~ 1800	
	WP4.1Q150				110/2600	500/1200 ~ 1800	
	WP4.1Q160				115/2600	520/1200 ~ 1800	

WP4/WP6 Model List

Series	Model	Emission	Displacement (L)	Per cylinder valve	Rated power/speed (kW/rpm)	Max.torque/speed (N.m/rpm)	Technical route
WP4	WP4.150	Euro III/IV/V	4.5	2	110/2300	550/1400-1600	Common rail+SCR
	WP4.165				121/2300	600/1400-1600	
	WP4.180				132/2300	660/1400-1600	
	WP6.200				147/2300	760/1200-1600	
WP6	WP6.220	Euro III/IV/V	6.75	2	162/2300	850/1200-1600	Common rail+SCR
	WP6.245				180/2300	900/1200-1600	

WP5/WP7 Model List

Series	Model	Emission	Displacement (L)	Per cylinder valve	Rated power/speed (kW/rpm)	Max.torque/speed (N.m/rpm)	Technical route
WP5	WP5.180	Euro III/IV/V	4.98	4	132/2100	780/1200-1700	Common rail+SCR
	WP5.200				147/2100	830/1200-1700	
	WP5.220				162/2100	840/1200-1700	
WP7	WP7.240	Euro III/IV/V	7.47	4	176/2100	1050/1200-1700	Common rail+SCR
	WP7.270				199/2100	1160/1200-1700	
	WP7.300				220/2100	1250/1200-1700	

WP9H/WP10H Model List

Series	Model	Emission	Displacement (L)	Per cylinder valve	Rated power/speed (kW/rpm)	Max.torque/speed (N.m/rpm)	Technical route
WP9H	WP9H290	Euro V	8.8	4	213/1900	1400/1000-1400	Common rail+SCR
	WP9H310				228/1900	1500/1000-1400	
	WP9H336				247/1900	1600/1000-1400	
	WP9H350				257/1900	1700/1100-1400	
WP10H	WP10H310	Euro V	9.5	4	228/1900	1500/1000-1400	Common rail+SCR
	WP10H336				247/1900	1600/1000-1400	
	WP10H350				257/1900	1700/1000-1400	
	WP10H375				276/1900	1800/1000-1400	
	WP10H400				294/1900	1850/1000-1400	

WP10 Model List

Series	Model	Emission	Displacement (L)	Per cylinder valve	Rated power/speed (kW/rpm)	Max.torque/speed (N.m/rpm)	Technical route
WP10	WP10.300N	Euro III	9.726	2	228/1900	1390/1200-1500	Common rail+SCR
	WP10.336N				247/1900	1500/1200-1500	
	WP10.375				276/2200	1460/1200-1600	
	WP10.310	EuroIV/ Euro V	9.726	4	228/1900	1500/1200-1500	Common rail+SCR
	WP10.336				247/1900	1550/1200-1500	
	WP10.350				257/1900	1600/1200-1600	
	WP10.375				276/1900	1650/1200-1600	

WP12 Model List

Series	Model	Emission	Displacement (L)	Per cylinder valve	Rated power/speed (kW/rpm)	Max.torque/speed (N.m/rpm)	Technical route
WP12	WP12.375N	Euro III	11.596	4	276/1900	1800/1000-1400	Common rail
	WP12.400N				294/1900	1920/1000-1400	
	WP12.430N				316/1900	2060/1000-1400	
	WP12.460N				338/1900	2110/1000-1400	
	WP12.375	EuroIV/ Euro V	11.596	4	276/1900	1800/1000-1400	Common rail+SCR
	WP12.400				294/1900	1920/1000-1400	
	WP12.430				316/1900	2060/1000-1400	
	WP12.460				338/1900	2110/1000-1400	

Gas Engine Model List

Series	Model	Emission	Displacement (L)	Per cylinder valve	Rated power/speed (kW/rpm)	Max.torque/speed (N.m/rpm)	Technical route
WP4.1NG	WP4.1NG100	Euro V	4.088	2	74/2600	350/1200-1800	Single point injection + oxidation catalysis
	WP4.1NG125				92/2600	400/1200-1800	
	WP4.1NG140				103/2600	450/1200-1800	
	WP4.1NG150				110/2600	500/1300-1800	
WP5NG	WP5NG165	Euro V	4.98	4	121/2100	600/1300-1500	Single point injection + oxidation catalysis
	WP5NG180				132/2100	650/1300-1500	
	WP5NG200				147/2100	665/1300-1500	
WP6NG	WP6NG210	Euro V	6.75	2	155/2300	720/1400-1600	Single point injection + oxidation catalysis
	WP6NG240				176/2300	780/1400-1600	
WP7NG	WP7NG240	Euro V	7.47	4	177/2100	900/1300-1500	Single point injection + oxidation catalysis
	WP7NG260				191/2100	1000/1300-1500	
	WP7NG270				199/2100	1050/1300-1500	
	WP7NG280				206/2100	1150/1300-1500	
WP10NG	WP10NG260	Euro V	9.726	2	191/1900	1200/1200-1500	Single point injection + oxidation catalysis
	WP10NG280				206/1900	1300/1200-1500	
	WP10NG300			4	220/1900	1400/1200-1500	
	WP10NG336				247/1900	1450/1200-1500	
WP12NG	WP12NG336	Euro V	11.596	4	247/1900	1560/1200-1400	Single point injection + oxidation catalysis
	WP12NG350				257/1900	1700/1200-1500	
	WP12NG380				280/1900	1700/1200-1500	
	WP12NG400				294/1900	1730/1200-1500	
	WP12NG400				294/2100	1700/1200-1500	
	WP12NG420				309/2100	1730/1200-1500	

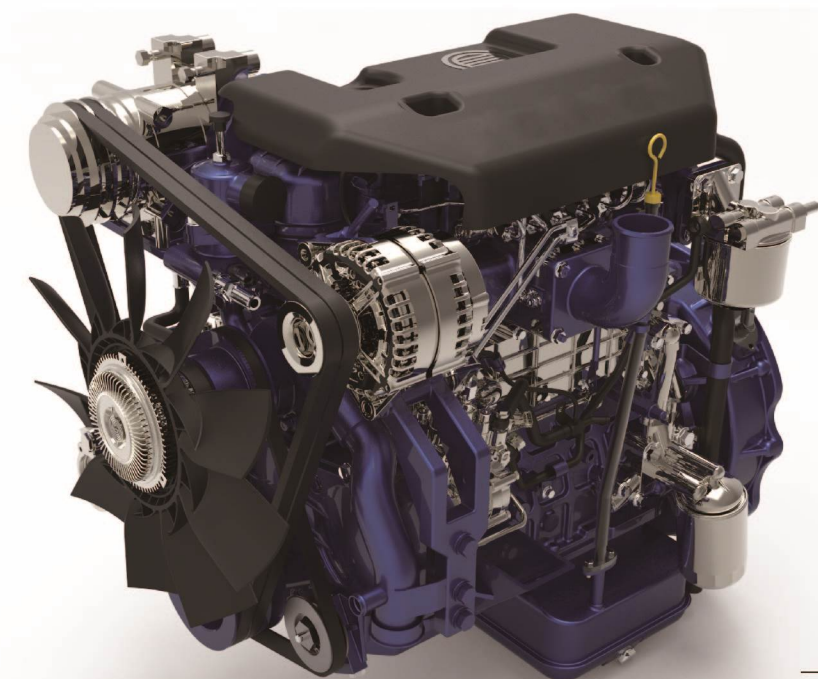

Major Engine Product for Bus



WP2.1
Engine Model

Specifications

Emission requirements: The series complies with China IV and V emission standards.

Dynamic performance: The series features high power and high torque (high torque @ low speed).

Economy: Optimized power train system provides low fuel consumption.

Low rpm and high mechanical efficiency help reduce fuel consumption.

NVH: Customized vehicle NVH development provides low noise, low vibration and structure support for A/C meets vehicle needs.

Versatility: Bosch ECU used in the fuel system maximizes the interchangeability of parts and components with those of other products on the same platform.

SPEC SHEET

Project	Disp (L)	Bore/Stroke (mm)	Rated power (kW)	Rated speed (rpm)
WP2.1	2.1	85×92	45-70	3200

Outline - WP2.1

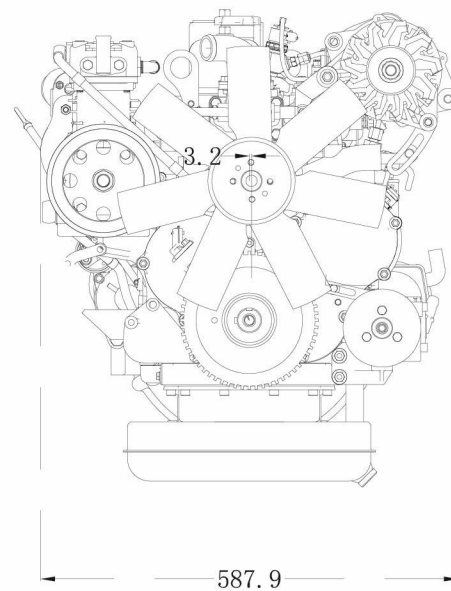
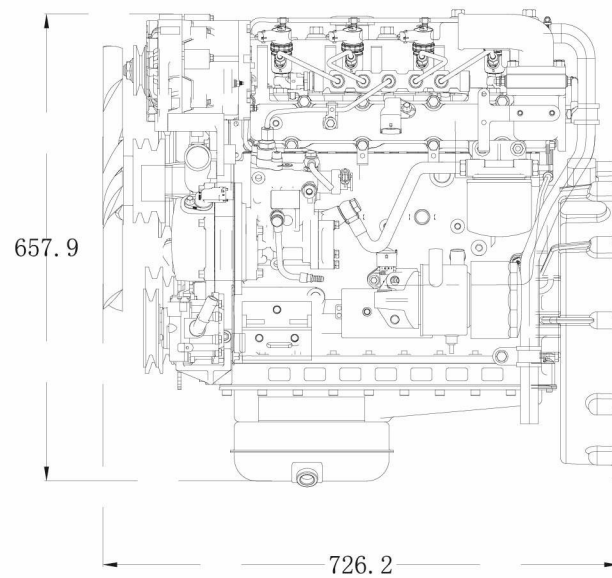

WP3
Engine Model

Specifications

Emission performance: The series complies with China IV and V emission standards.

Dynamic performance: The displacement is 0.2L higher than other diesel engines of the same type.

Low speed and high torque provides excellent acceleration.

Large displacement (7% higher than competitors of the same horsepower) ensures powerful starting and acceleration.

Large torque (13% higher than competitors of the same horsepower) ensures high gradeability and overloading capacity.

Economy: Optimized power train system provides low fuel consumption.

Low rpm and high mechanical efficiency help reduce fuel consumption.

A silicon oil fan saves oil by 3% as compared to the traditional rigid one.

NVH: Customized vehicle NVH development provides low noise, low vibration and structure support for A/C meets vehicle needs.

SPEC SHEET

Project	Disp (L)	Bore/Stroke (mm)	Rated power (kW)	Rated speed (rpm)
WP3	3	94×107	81-96	3000

Outline - WP3

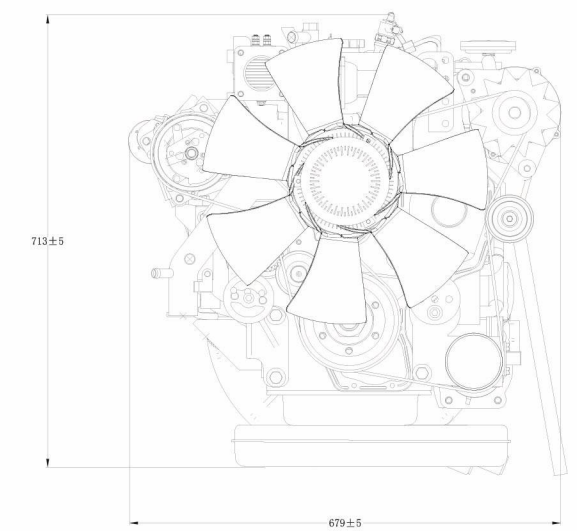
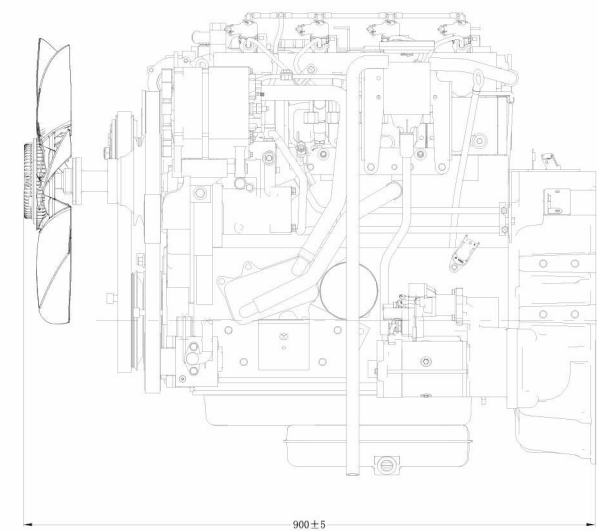



WP3.7/WP4.1 Engine Model

Specifications

Emission requirements: The series complies with China IV and V emission standards.

Dynamic performance: Low speed and high torque provides excellent acceleration.

Economy: Optimized power train system provides low fuel consumption.

Low rpm and high mechanical efficiency help reduce fuel consumption.

NVH: An automatic tensioning structure for multi-wedge belt in the front wheel train provides low vibration and noise.

Safety: A monobloc thermal shroud provides safety and aesthetics.

Adaptability: The front-end of engine can cater for dual dynamo arrangement and structure support for A/C to meet vehicle needs.

SPEC SHEET

Project	Disp (L)	Bore/Stroke (mm)	Rated power (kW)	Rated speed (rpm)
WP3.7	3.7	102×112	75-96	2900
WP4.1	4.1	105×118	97-115	2600

Outline - WP3.7/WP4.1

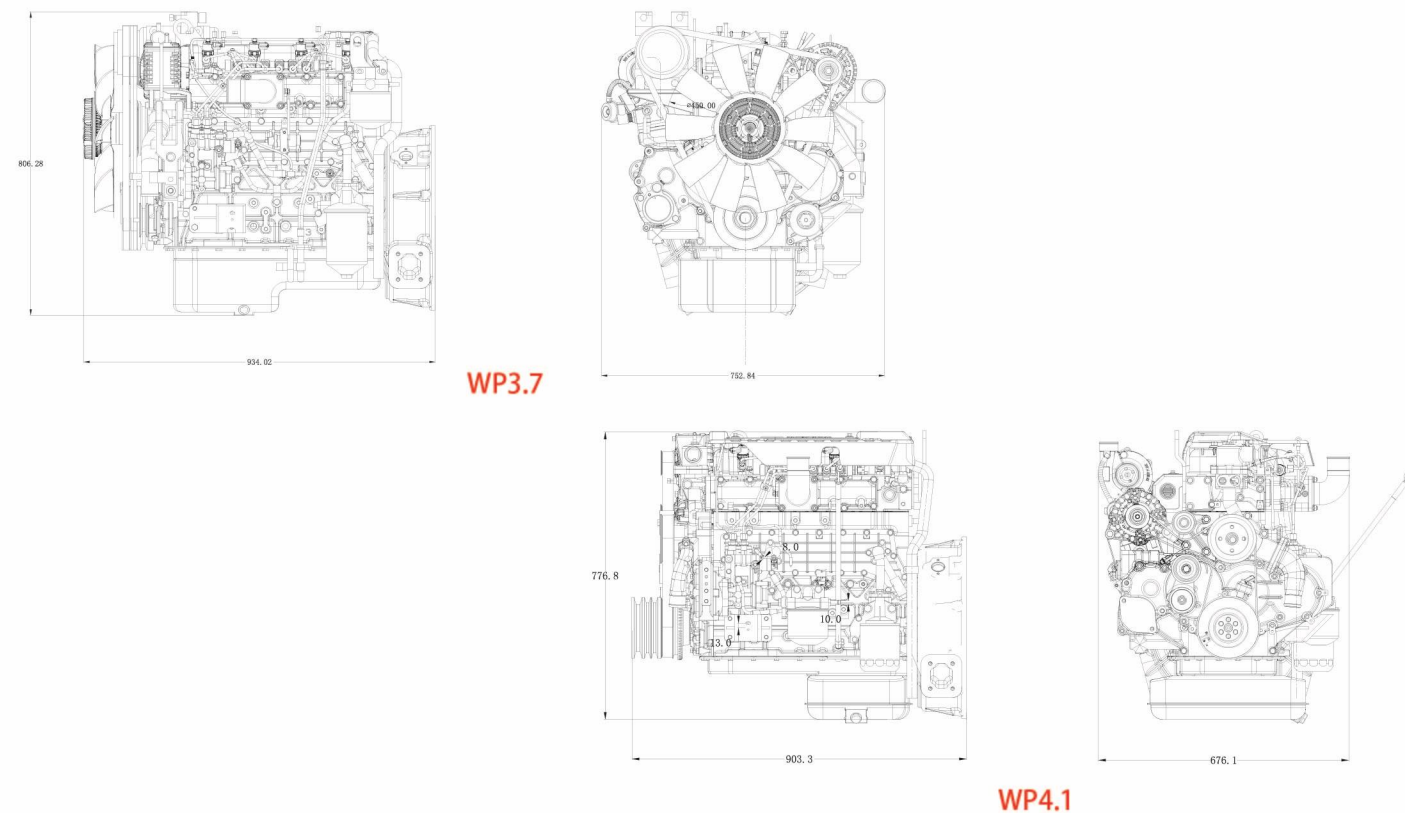

WP4 Engine Model

Specifications

Emission requirements: Bosch's EDC17 high-pressure common rail system provides accurate control and compliance with China IV and V emission standards.

Dynamic performance: The series features much better torque, sufficient reserve of low-speed torque, and considerably improved acceleration and dynamic performance of vehicles over competitors.

Economy: As the economic range of fuel consumption shifts towards the low speed range, fuel consumption can be reduced if engines are kept working in such a low speed range by reasonably matching the gearbox and axles. This will result in significantly improved economy over competitors.

NVH: A 2-stage balance structure minimizes vibration, extends service life of engine components, and improves comfort.

Reliability: The combustion system, intake and exhaust system, and cooling system are fully improved in their design. A multi-wedge belt structure provides more efficient transmission, smooth operation, and low failure rate.

SPEC SHEET

Project	Disp (L)	Bore/Stroke (mm)	Rated power (kW)	Rated speed (rpm)
WP4	4.5	105/130	110-132	2300

Outline - WP4

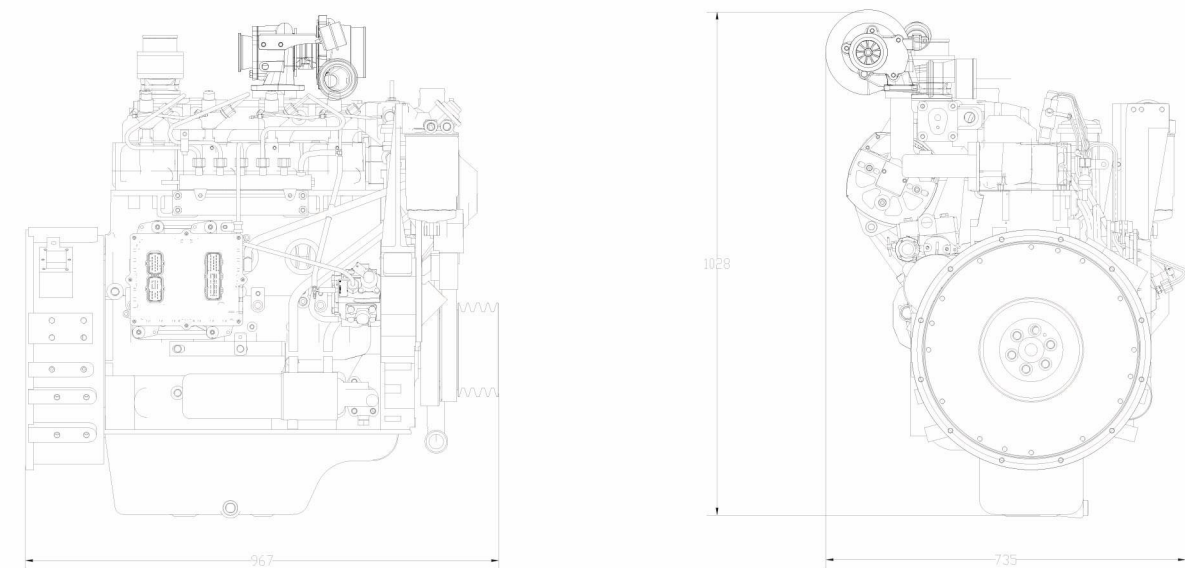

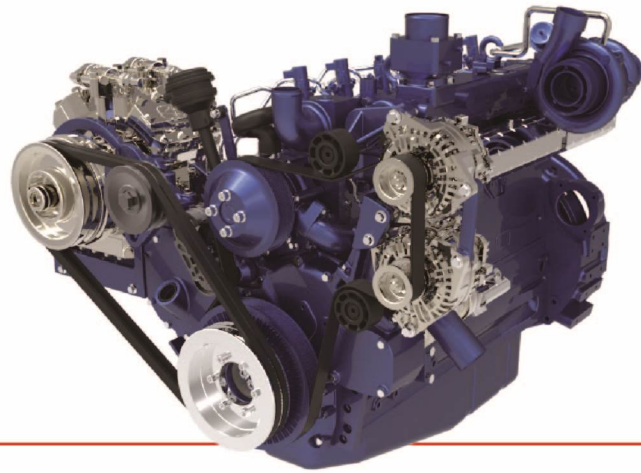

WP6
Engine Model

Technical Specifications

- Emission requirements:** Bosch's EDC17 high-pressure common rail system provides accurate control and compliance with China IV and V emission standards.
- Dynamic performance:** The series features much better torque and sufficient reserve of low-speed torque as compared to competitors. The max. torque is increased to 900N•m, providing better acceleration and dynamic performance.
- Economy:** An elevated cooling structure improves engine cooling outcome and decreases fuel consumption by 6g/kW•h, making the engine a golden choice for fuel economy.
- NVH:** An automatic tensioning structure for multi-wedge belt on the front end enables the engine to work at low vibration and more quietly and makes vehicles more comfortable.
- Adaptability:** The front-end of engine can cater for single or dual dynamo and structure support for A/C to meet vehicle needs.
- Reliability:** High reliability comes from the lowered turbocharger, reinforced body structure, and the fully improved design of the combustion system, intake and exhaust system, and cooling system.
- Cost-effectiveness:** Low procurement and operating cost results in product cost-effectiveness.

SPEC SHEET

Project	Disp (L)	Bore/Stroke (mm)	Rated power (kW)	Rated speed (rpm)
WP6	6.75	105/130	147-180	2300

Outline - WP6

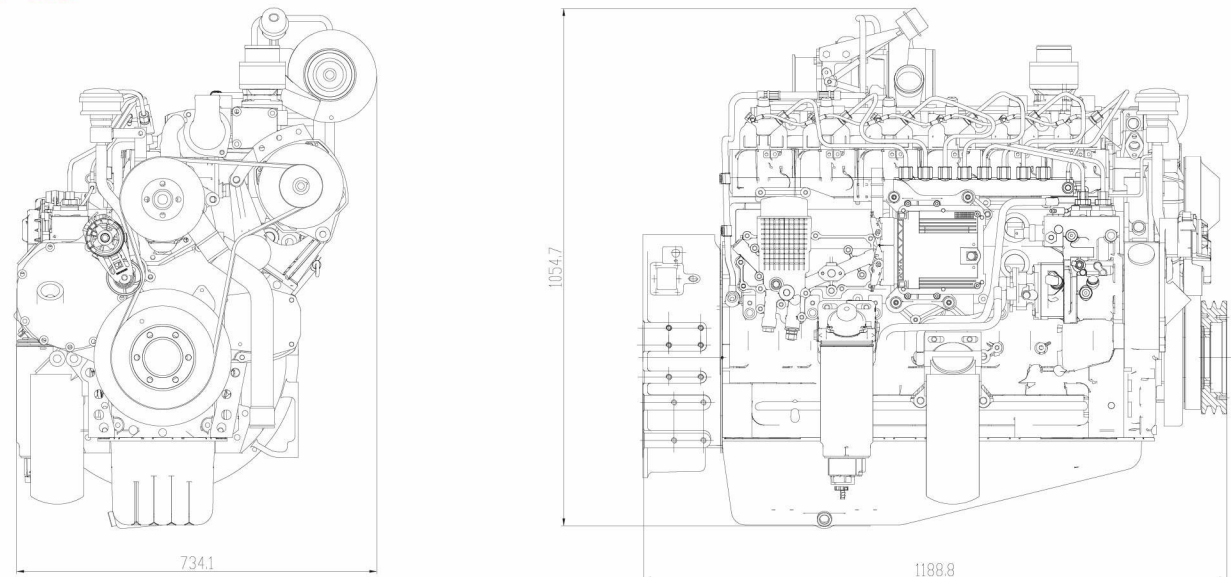

WP5/7
Engine Model

Specifications

- Emission:** Euro IV, V
- Economy :** The lowest fuel consumption is 195g/(kWh) and engine economic speed is from 1200 r/min to 1800r/min . From adjusting the vehicle configuration which uses the small single ration, WP5/WP7 comprehensive fuel consumption is significantly better than competing products
- Dynamic :** Maximum power and torque are superior to competing products.ti has the good performance of climbing and the starting
- Comfort:** Compared with the mainstream product,WP5/WP7 have the low vibration and noise, 2dB (A) lower than that of competitive products

SPEC SHEET

Project	Disp (L)	Bore/Stroke (mm)	Rated power (kW)	Rated speed (rpm)
WP5	4.98	108×136	132-192	2100
WP7	7.5	108×136	176-220	2100

Outline - WP5/7

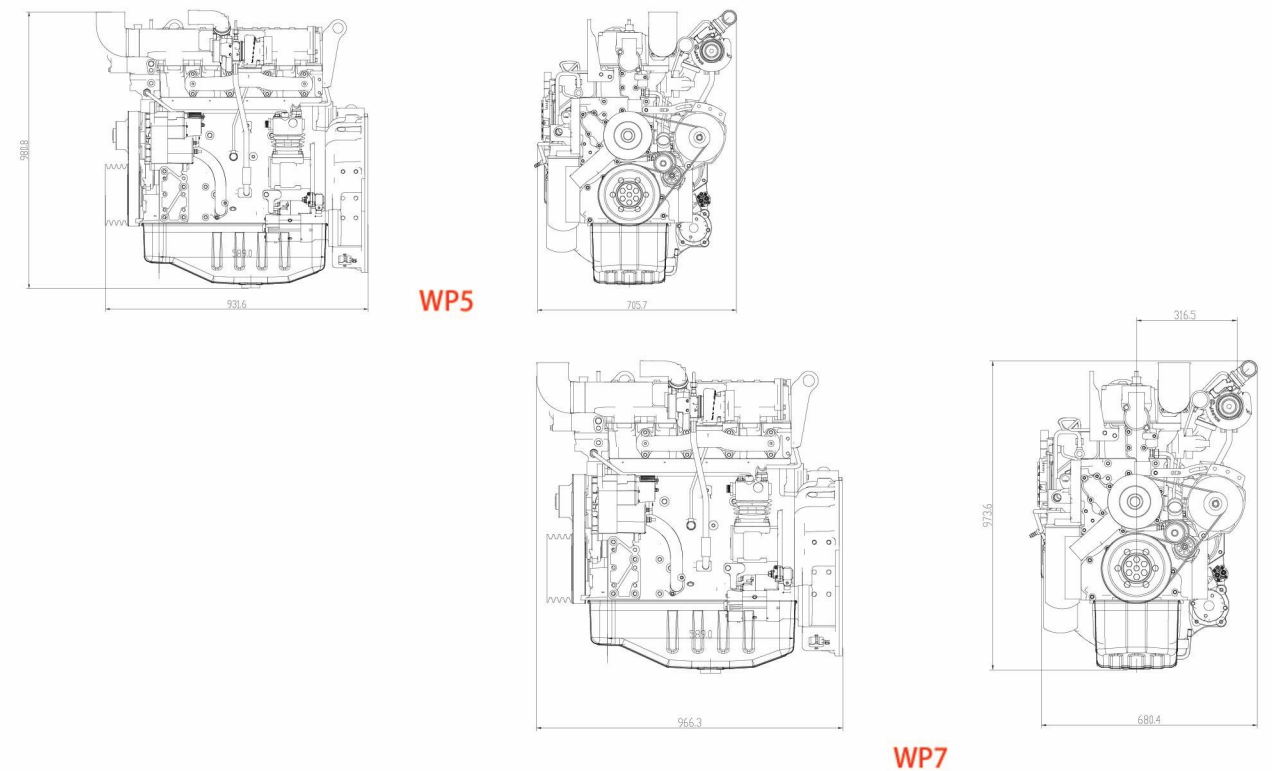

WP9H/WP10H Engine Model

Specifications

Emission requirements: As the first batch of engines launched on Weichai's new-generation diesel engine platform, the series complies with China V and Euro VI emission standards.

Dynamic performance: Low speed and high torque provide significantly advantageous dynamic performance over peers in terms of gradeability and acceleration.

Economy: A newly designed combustion system improves fuel efficiency and ensures ultra-low fuel consumption. Reasonable matching of gearbox and axles keeps the engine working in the low speed range to reduce fuel consumption.

NVH: Fully utilizing latest design concept and new materials and processes, the engines run at significantly reduced vibration and noise.

Adaptability: The front-end of engine can cater for single, dual, or triple dynamo and structure support for A/C to meet vehicle needs.

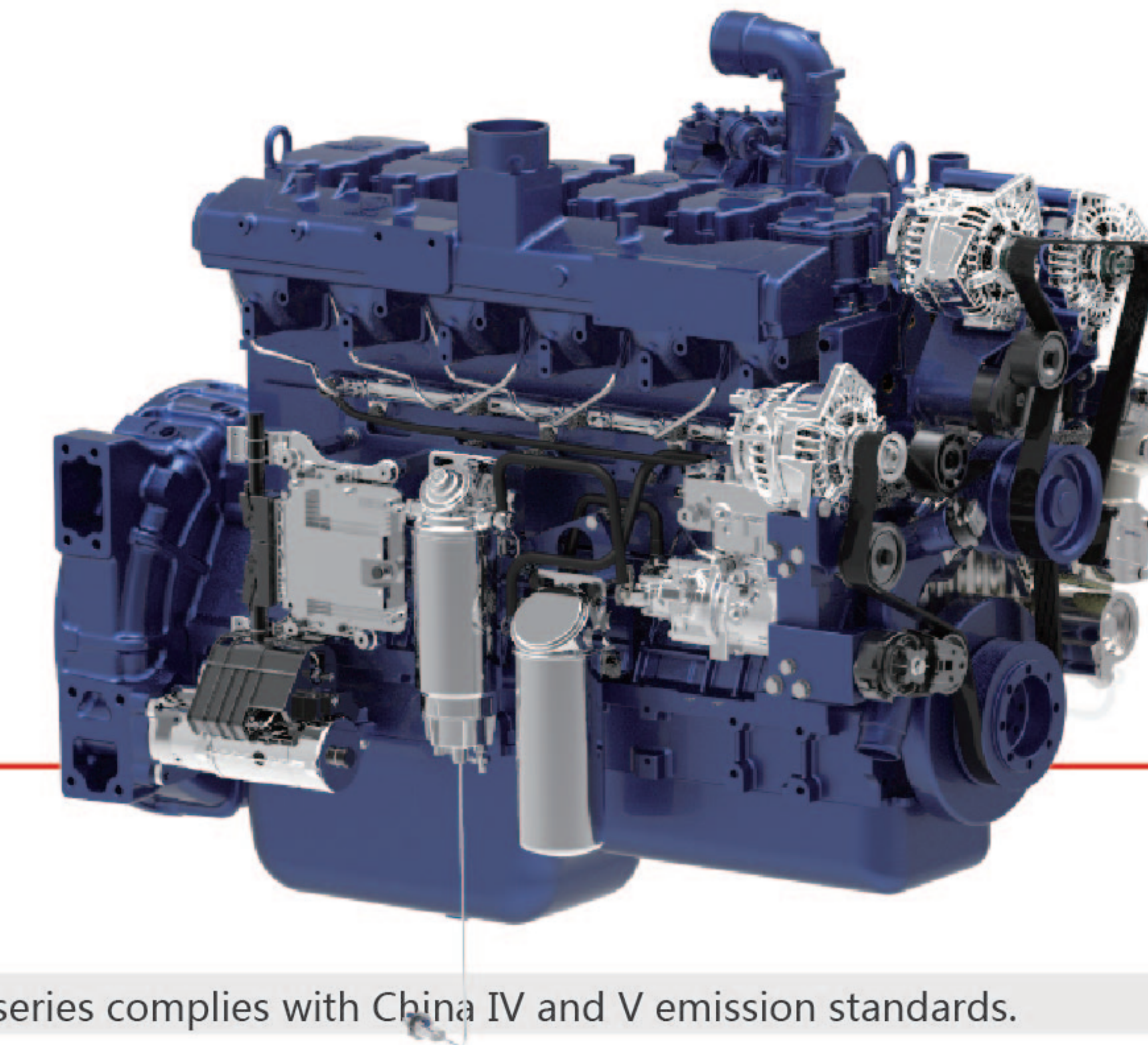

WP10 Engine Model

Specifications

Emission requirements: The series complies with China IV and V emission standards.

Dynamic performance: A four-valve structure enables the engine to be powerful with low speed and high torque.

Economy: The fuel consumption is low.

NVH: An automatic tensioning structure for multi-wedge belt on the front end enables the engine to work at low vibration and more quietly and makes vehicles more comfortable.

Adaptability: The front-end of engine can cater for dual or triple dynamo and structure support for A/C can meet the needs of different users.

SPEC SHEET

Project	Disp (L)	Bore/Stroke (mm)	Rated power (kW)	Rated speed (rpm)
WP10	9.726	126/130	228-276	1900

Outline - WP10

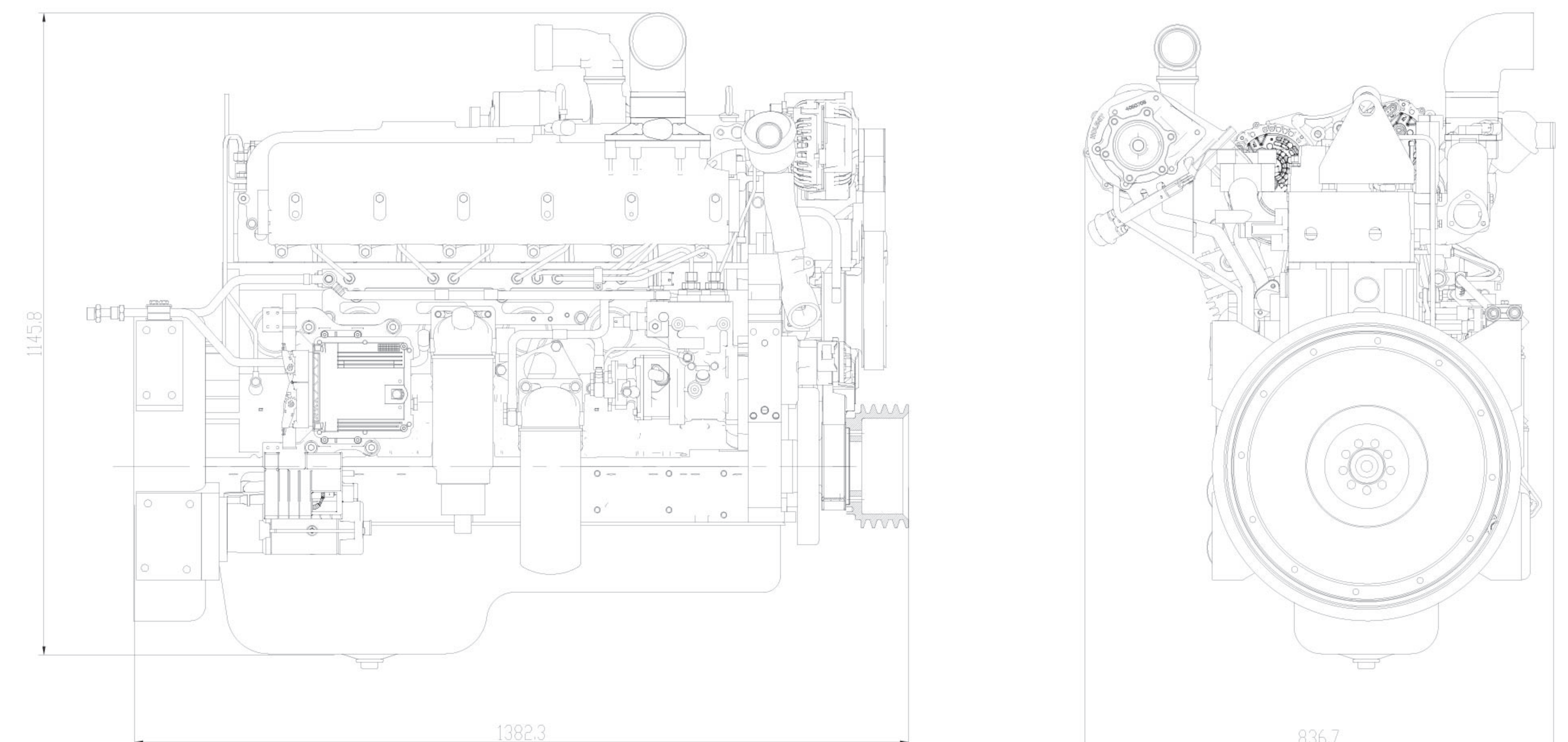

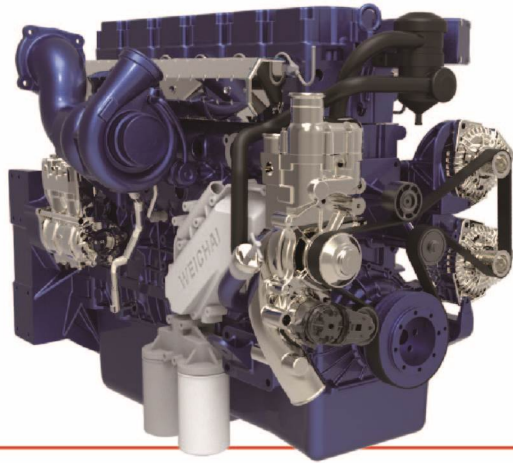

WP12
Engine Model

Specifications

The series is jointly developed by Weichai's European R&D Centre and Austrian AVL.

Emission requirements: The series complies with China IV and V emission standards.

Dynamic performance: These are powerful engines with low speed and high torque.

Economy: The fuel consumption is low.

NVH: Complete MAP noise optimization and NVH noise optimization provide excellent comfort.

Adaptability: The front-end of engine can cater for dual or triple dynamo and structure support for A/C can meet the needs of different users.

SPEC SHEET

Project	Disp (L)	Bore/Stroke (mm)	Rated power (kW)	Rated speed (rpm)
WP12	11.596	126/155	276-338	1900

Outline - WP12

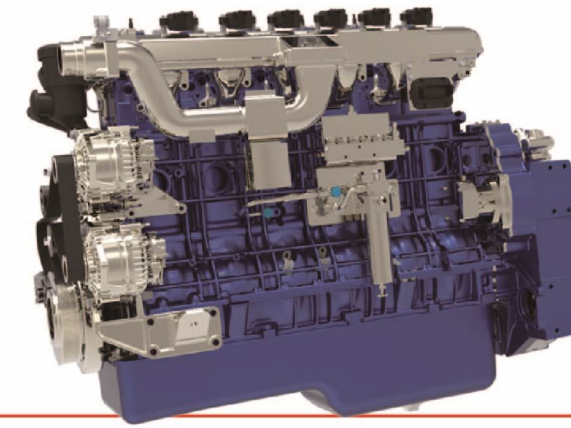
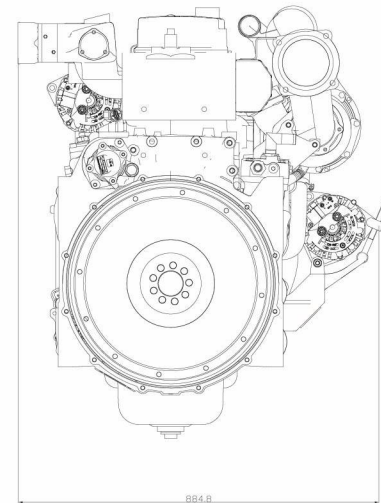
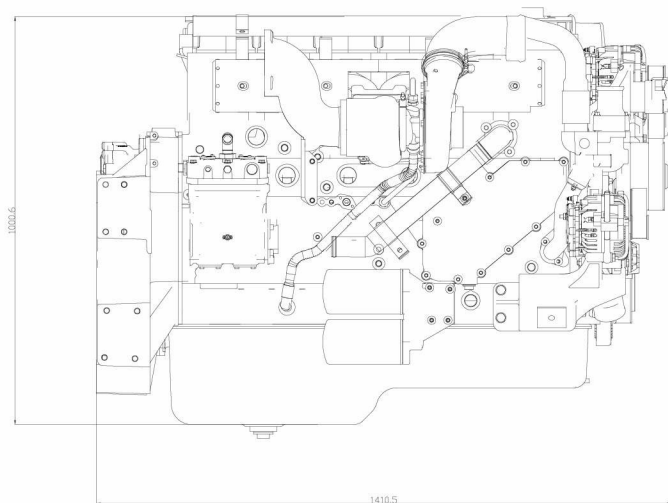

WP12NG
Engine Model

Specifications

Emission requirements: Woodward's latest electronic control for single-point injection provides compliance with China V emission standard.

Dynamic performance: A four-valve structure improves low-speed and max. torque, leading to much better response at acceleration and starting.

Economy: With the rated speed lowered to 1,900 RPM, the engines see a 3% drop of absolute gas consumption in stand tests and an extended range of speed with low gas consumption.

The economic range of gas consumption shifts towards the low speed range. Enhanced squish enables faster combustion. Intelligent spark coils increase ignition energy, thereby reducing cycle-by-cycle load variation at low-speed portion as well as specific gas consumption.

The gas consumption of vehicles can be further decreased if rear axles of low gear ratio are used.

Reliability: A new ECU that is so resistant to heat, vibration, and EMI that it can be directly mounted on the engine.

NVH: The series boasts low vibration and is quieter than competitors by 2dB.

SPEC SHEET

Project	Disp (L)	Bore/Stroke (mm)	Rated power (kW)	Rated speed (rpm)
WP12NG	11.596	126/155	247-309	2100

Outline - WP12NG

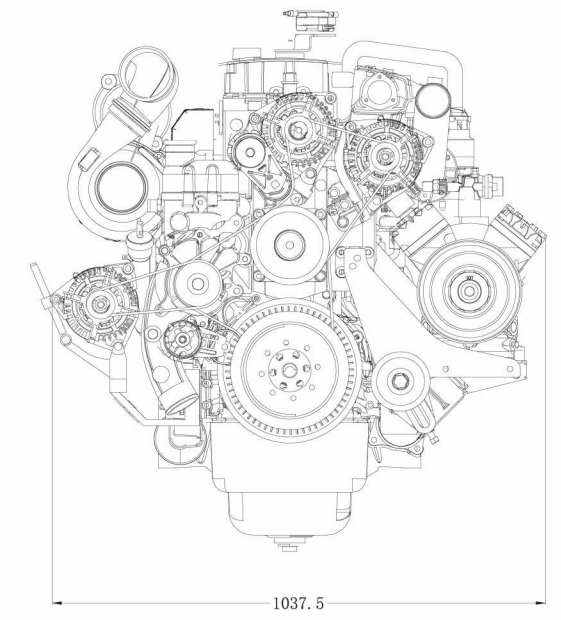
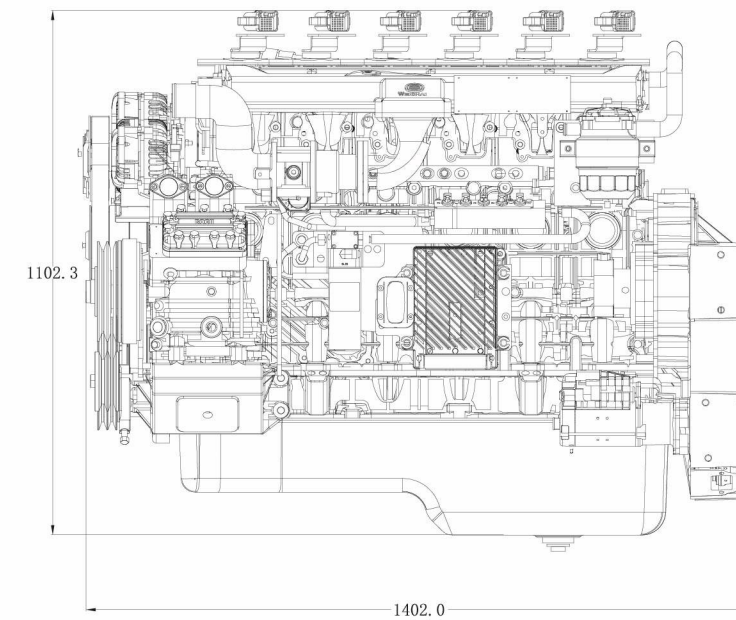

Weichai Service

Products of Weichai Power have been sold to 100 countries and regions on five continents. Currently, a worldwide service network had been established with 35 foreign field offices and and over 400 authorized service locations.

Also, Weichai has set up global operation centers in Wiesbaden/ Aschaffenburg (Germany), Forli (Italy), Marseilles (France), Chicago(USA), and Singapore, etc.

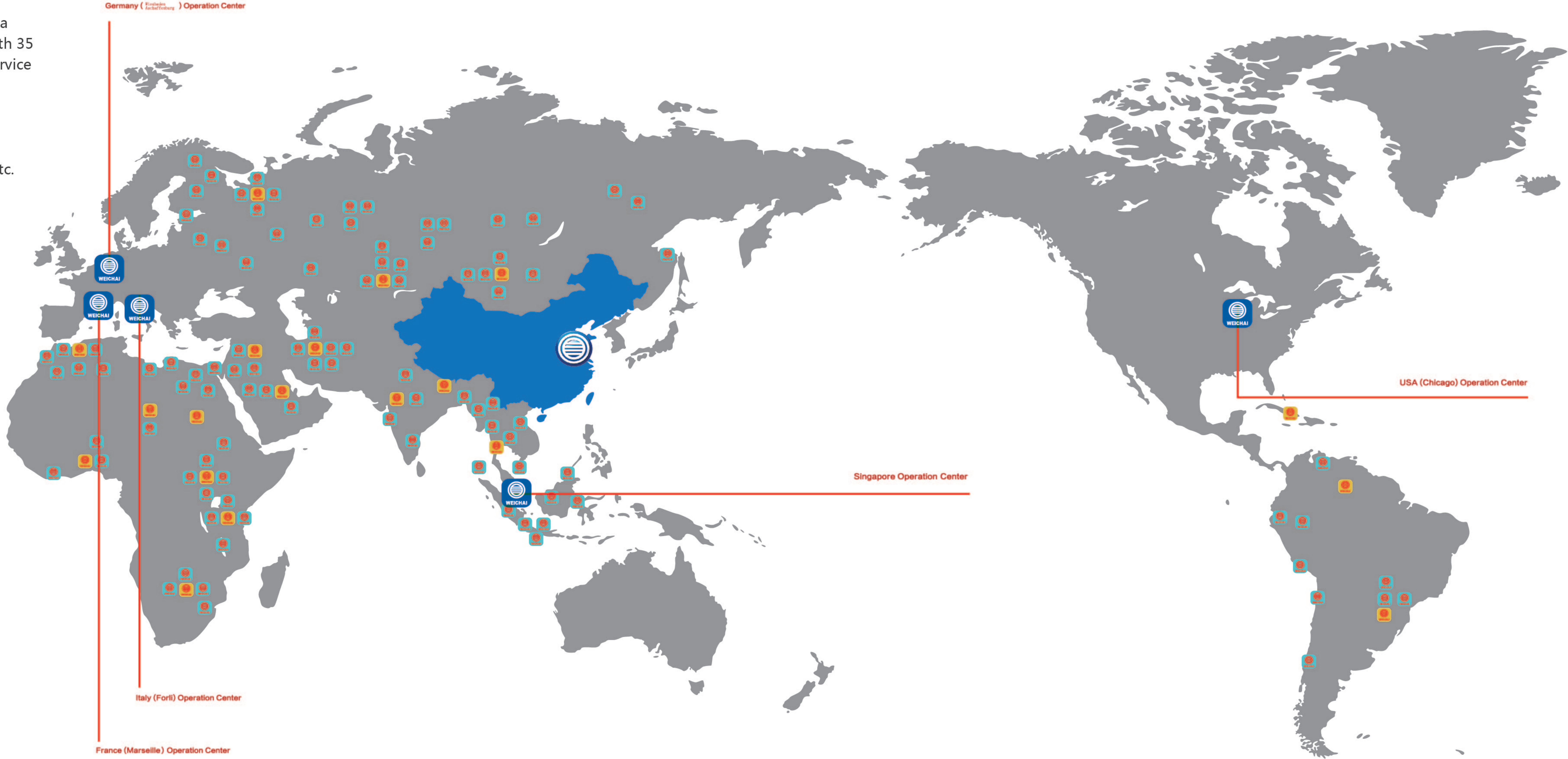

-  **Operation Center**
-  **Overseas Representative Office**
-  **Authorized Service Station**